

SPECIFICATION FOR APPROVAL

Customer : _____
Description CENTRIFUGAL FAN
Customer Part No: _____ REV: _____
Fulltech Model No: UF-190APA23H1C2A REV: 00
Issue Date: MAR.31.20

PLEASE SEND ONE COPY OF THIS SPECIFICATION BACK AFTER YOU
SIGNED APPROVAL FOR PRODUCTION PRE-ARRANGMENT.

APPROVED BY:

DATE:

FULLTECH ELECTRIC CO., LTD
NO.31, NEI-SHI ROAD, LU-CHU DISTRICT 33852,
TAOYUAN CITY, TAIWAN, R.O.C.
TEL: 886-3-3246161
FAX: 886-3-3245596



HISTORY

CUSTOMER: _____

CUSTOMER P/N: _____

FULLTECH MODEL: UF-190APA23H1C2A

REV	DESCRIPTION	DRAWN	CHECKED	APPROVED	ISSUE DATE

SPECIFICATIONS

ITEM \ MODEL	UF-190APA23H1C2A
RATED VOLTAGE	AC230V
VOLTAGE RANGE	AC207-253V
SPEED(RPM)	50Hz 2350 RPM±10% 60Hz 2550 RPM±10%
RATED CURRENT	50Hz 0.24 A±10% 60Hz 0.30 A±10%
RATED INPUT	50Hz 55 W±10% 60Hz 66 W±10%
LOCKED CURRENT	50Hz 0.33 A±10% 60Hz 0.36 A±10%
MAX.AIR VOLUME	50Hz 335±10% CFM 60Hz 370±10% CFM
MAX.STATIC PRESSURE	50Hz 1.0±10% inH2O 60Hz 1.2±10% inH2O
OPERATING TEMP.	-40°C ~ + 65°C
MAX. OPERATING HUMIDITY	85%
STORAGE TEMP.	-40°C ~ + 80°C
ROTATING DIRECTION	CLOCKWISE DIRECTION
INSULATION RESISTANCE	DC 500 V 100MΩ
DIELECTRIC STRENGTH	AC 1500V / 1MIN
NOISE	50Hz 60 (Max.65) dB 60Hz 63 (Max.68) dB
SAFETY PROTECTION	THERMAL PROTECTION
INSULATION GRADE	CLASS B
BEARING	BALL BEARING
LIFE EXPECTANCY	OVER 40000 HOURS (40°C)
IMPELLER	PLASTIC PA COVERING GLASS FIBER
CAPACITOR	2uF/450V
DIMENSION	190 mm dia
WEIGHT	1.2 KGS

NOTES:

1. ALL READINGS ARE MEASURED AFTER STABLY WARMING UP THROUGH 30 MINUTES.
2. STANDARD AIR PROPERTY IS AIR AT (Td) 25°C TEMPER ATURE, (RH) 65% RELATIVE HUMIDITY , AND (Pb) 760 mmHg BAROMETRIC PRESSURE.
3. ACOUSTICAL NOISE MEASURING CONDITION:

CENTRIFUGAL FAN

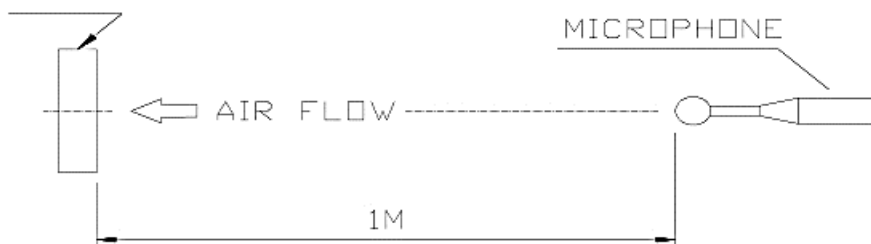

4. NOISE IS MEASURED AT RATED VOLTAGE IN FREE AIR IN A SEMI-ANECHOIC CHAMBER WITH A & D SOUND LEVEL METER WITH MICROPHONE AT A DISTANCE OF ONE METER FROM THE FAN INTAKE.

PRODUCT DRAWING

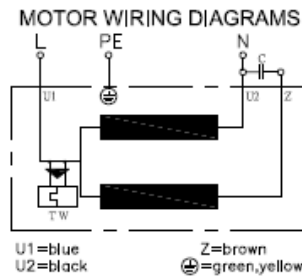
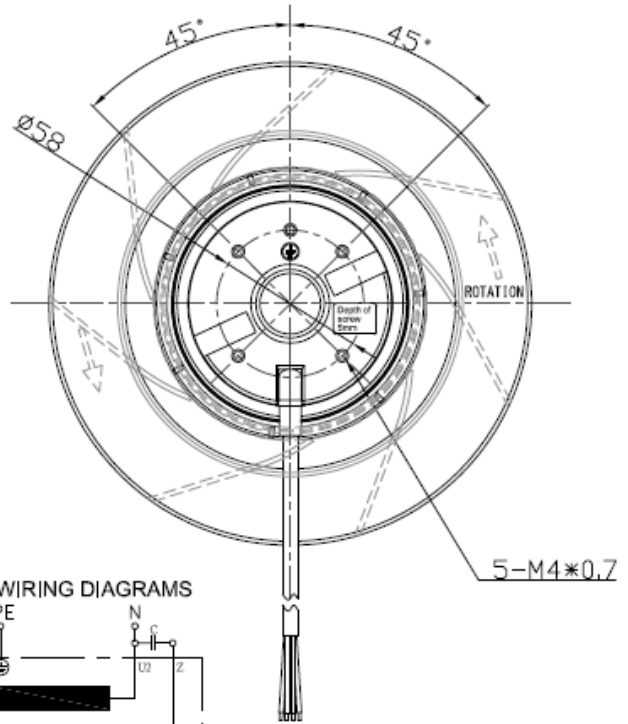
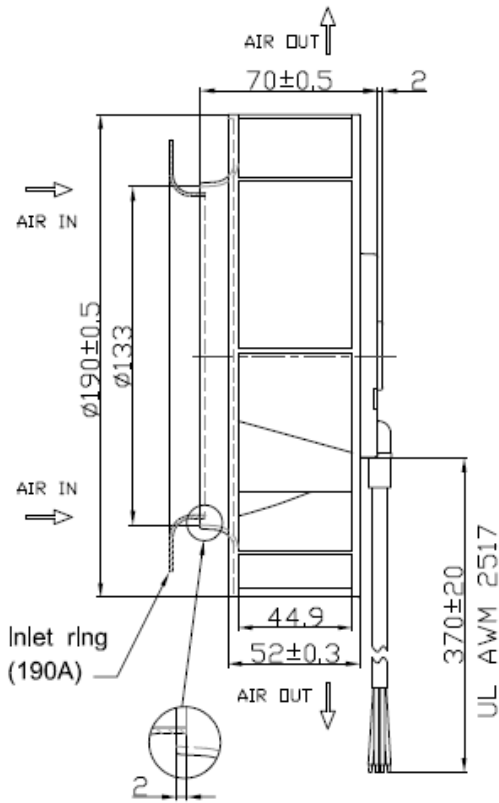

Lead wire Type MODEL: UF190APA

AIR FLOW-STATIC PRESSURE CURVE

品名：離心扇

測試日期：2015/9/25

規格：UF - 190APA23H1C2A

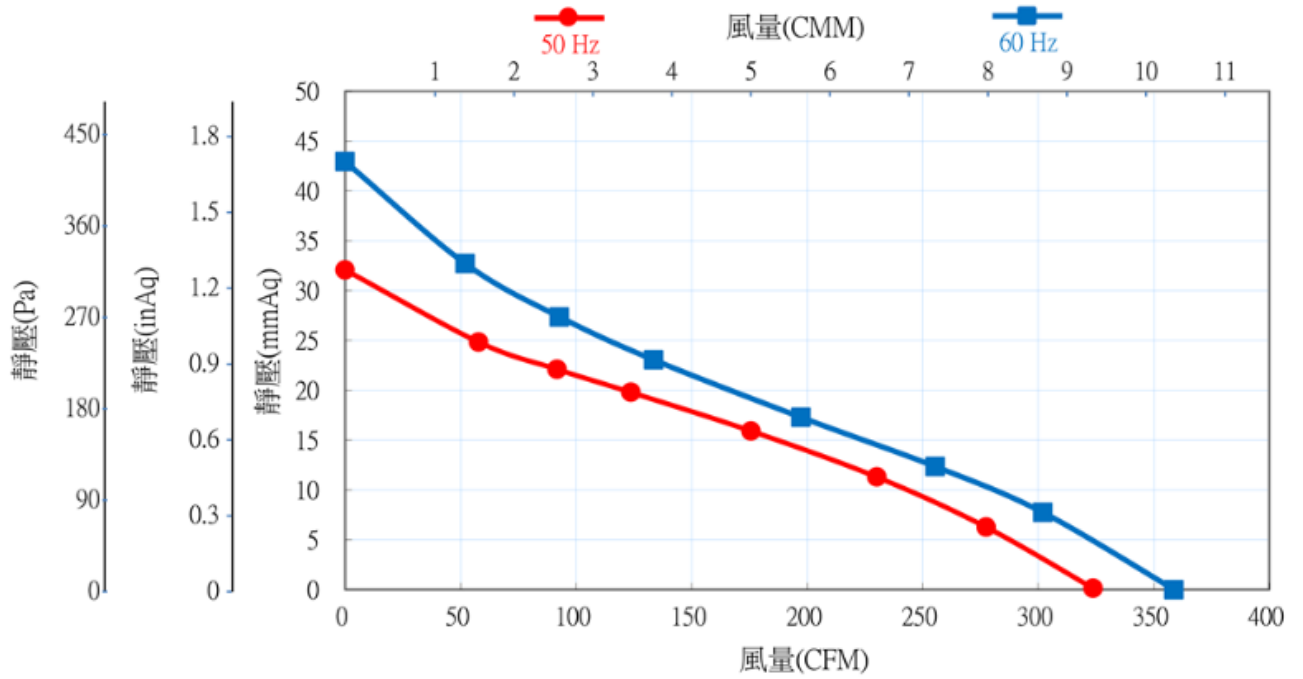

Operating Manual

1. SAFETY REGULATIONS AND INFORMATION

- Read following operating instructions carefully before starting work on the device. Observe the following warnings to prevent machine malfunctions or danger to persons.
- These operating instructions maybe duplicated and distributed to inform about the potential dangers.

1.1 Staff Qualifications

- The device may only be transported, unpacked, installed, operated, maintained and otherwise used by qualified, trained and authorized technical staff.
- Authorized specialists are preferred to install the device with the electrical installation and carry out the test run.

1.2 Basic safety rules

- Please make sure the product is being installed and used in compliance with all safety standards.
- The locally applicable industrial safety regulations are always to be observed when working on the device.
- Please handle and install the product with caution. Hit or drop the product may cause possible damage.
- Please do not damage the product, especially the coil or lead wires during the installation, which may cause the possible smoke or fire.
- Fulltech Electric Co., Ltd.'s product warranty will not extend if your application exceeds the limitation of product specification.

1.3 Mechanical movement

- Risk of injury to body parts if coming into contact with the rotor or the impeller.
- Secure the device against accidental contact
- Before working on the system/machine, wait till all parts come to a standstill.
- Fulltech recommends to protect the fan from exposure to outside elements, such as dust, condensation, humidity or insects. Exposure of this fan to outside elements such as dust, condensation, humidity or insects may effect the fan performance and cause the safety concern.

1.4 Transportation

- Transport the fan in its original packaging is preferred.

1.5 Storage

- Please follow the requirement on product specification for fan storage. Make sure that fan will dry and clean and free from vibration.
- Please “do not” store the fan in a high humidity environment. If this fan is stored over 6 months, Fulltech suggests functional testing before using.